

# Spring Steel Fasteners

## Cover Plate Mounting Brackets

- Replaces electrical box in Class 2 low voltage installations
- Provides attachment base for low voltage outlets: antenna, audio, computer, telephone and security
- Provides rigid support when installed with screws that are provided
- Maximum 1<sup>1</sup>/<sub>4</sub>" (31.7mm) drywall thickness
- Finish: Pre-galvanized

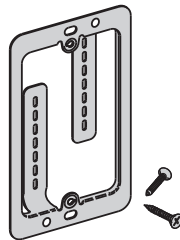
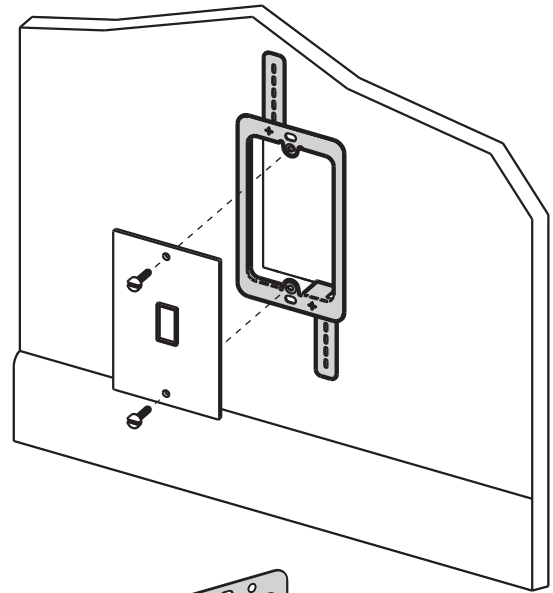

BB10L

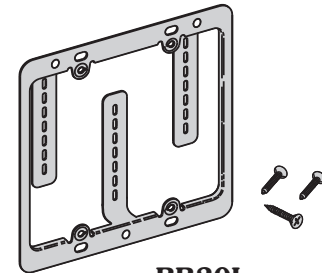

BB20L

| Part Number | Description         | Wt. Per Pc. |       |
|-------------|---------------------|-------------|-------|
|             |                     | Lbs.        | (kg)  |
| BB10L       | Single Gang Bracket | 7.6         | (3.4) |
| BB20L       | Double Gang Bracket | 10.4        | (4.7) |



Popular Bee List item

## Plastic Cover Plate Mounting Bracket

- Provides attachment base for low voltage outlets
- Replaces electrical box in Class 2 low voltage installations
- Design eliminates sharp edges from bracket
- Maximum wall thickness: 3/4"

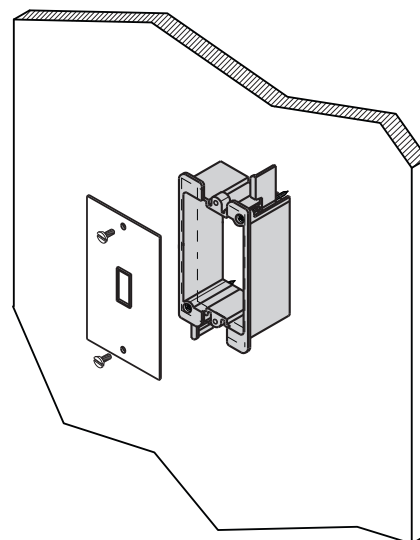
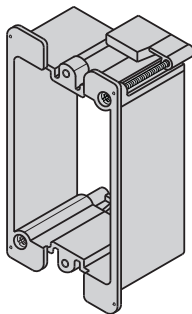

| Part Number | Wt. Per 100 |       |
|-------------|-------------|-------|
|             | Lbs.        | (kg)  |
| BB10P       | 6.0         | (2.7) |



Popular Bee List item